

The Effect of Gender and Arm Anatomical Position on the Hand Grip Strength and Fatigue Resistance during Sustained Maximal Handgrip Effort

Sami Faris Almashaqbeh^{1*}, Sajidah Al-Momani², Ateka Khader³, Qasem Qananwah⁴, Saja Marabeh⁵, Rand Maabreh⁵, Ayat Al badarneh⁵, Kawther Abdullah⁵

ABSTRACT

Background: Handgrip or Grip strength (GS) is a common method used to evaluate muscle strength and affected by different factors, including age, gender, and arm's positions.

Objective: This study aims to investigate the effect of both the gender and arm's positions on the handgrip strength and the fatigue resistance (FR), which is the time needed for the handgrip strength to drop to 75% (FR₇₅), 50% (FR₅₀), and 25% (FR₂₅) of its maximum strength during sustained maximal handgrip effort.

Material and Methods: In this experimental study, 59 male and 41 female participants were asked to grip forcefully on a dynamometer for the longest period. GS and FR₇₅, FR₅₀, and FR₂₅ values were recorded for 7 different arm positions. Factorial ANOVA was used to find the main effect of gender and position and the interaction between them. Sidak and Tukey's HSD tests were used to find the gender and arm position effects, respectively.

Results: The results showed a significant effect for gender and arm position on GS and FR and a significant interaction effect for GS that was significantly higher in males than females for all positions. The gender difference in FR depends on arm's positions and the level at which the FR was measured. GS was higher when arm adduction with 90° forward at the elbow as compared to arm abduction with 180° at the shoulder and 90° at the elbow.

Conclusion: The results confirmed the significant effect of the gender and arm's positions on the maximal handgrip strength and fatigue resistance during sustained maximal handgrip effort.

Citation: Almashaqbeh SF, Al-Momani S, Khader A, Qananwah Q, Marabeh S, Maabreh R, Al badarneh A, Abdullah K. The Effect of Gender and Arm Anatomical Position on the Hand Grip Strength and Fatigue Resistance during Sustained Maximal Handgrip Effort. *J Biomed Phys Eng.* 2022;12(2):171-180. doi: 10.31661/jbpe.v0i0.2009-1197.

Keywords

Isometric Exercise; Dynamometer; Handgrip Strength; Fatigue; Gender; Arm Position; Muscular Contraction; Posture

Introduction

Handgrip strength is a simple and cheap evaluation way that could be used to measure muscle strength. Thirty-five muscles are involved in the movement of the forearm and hand. A lot of these muscles play a crucial role in gripping. During gripping, flexor muscles create grip strength and the extensor muscles of the forearm stabilize the

¹MSc, Department of Biomedical Systems and Informatics Engineering, Hijjawi Faculty for Engineering Technology, Yarmouk University, Irbid, 21163, Jordan

²MSc, Biomedical Engineering Graduate Program, Engineering Faculty, American University of Sharjah, Sharjah, 26666, United Arab Emirates

³PhD, Department of Biomedical Systems and Informatics Engineering, Hijjawi Faculty for Engineering Technology, Irbid, 21163, Jordan

⁴PhD, Department of Biomedical Systems and Informatics Engineering, Hijjawi Faculty for Engineering Technology, Yarmouk University, Irbid, 21163, Jordan

⁵BSc, Department of Biomedical Systems and Informatics Engineering, Hijjawi Faculty for Engineering Technology, Yarmouk University, Irbid, 21163, Jordan

*Corresponding author: Sami Faris Almashaqbeh Department of Biomedical Systems and Informatics Engineering, Hijjawi Faculty for Engineering Technology, Yarmouk University, Irbid, 21163, Jordan
E-mail: Sami.m@yu.edu.jo

Received: 28 September 2020
Accepted: 10 December 2020

wrist [1]. A dynamometer that has high test-retest reliability is usually used to measure the handgrip strength [2]. Handgrip strength is usually used to predict the whole body strength in both genders as well as different ages [3], and also predict the forearm and hand muscles performance [4]. Some sports, such as wrestling, tennis, handball, and basketball require a degree of grip strength. Coaches and athletes could use the handgrip strength test as an assessment method [1]. Also, handgrip strength could be used to determine the nutritional status, health status, and the mortality in elderly. It is also known that lower handgrip strength could be related to a higher subsequent risk of poor health [5-8]. In medical research, handgrip strength is usually used to detect altering muscle strength associated with sarcopenia [9], and frailty [10]. Grip strength could be used as a biomarker for overall strength, upper limb function, bone mineral density, fractures, and quality of life [11-13].

Handgrip strength is affected by physiological factors, including age, gender, weight, hand size, upper arm size etc. Many studies have been conducted to investigate the difference in handgrip strength in relation to gender [14-17]. In general, males generate higher maximum handgrip force compared to females. However, different handgrip force values were reported in the literature. This variation may be due to differences in body posture and arm anatomical positions adopted by each study. For instance, Elsaï and Mohammad [18] have studied the effect of body posture on handgrip strength. They found that the handgrip strength was higher in standing posture compared to supine, side-lying, prone, and sitting postures. In their study, the shoulder was adducted with 90° flexion at the elbow joint and maintained in this position for all body postures. Handgrip strength is also affected by the arm's anatomical position. Various studies have focused on the influence of shoulder positioning angle and the role of different elbow angles on the handgrip force [19-21]. Furthermore, Alkurdi and Dweiri have investigated the effect of differ-

ent arm anatomical positions on the handgrip strength for 20 male subjects only while the subjects were in standing posture [22]. There were some differences in the handgrip strength for different arm positions.

Muscle fatigue is defined as a reduction in the capacity of the muscle to generate force [23]. It could be due to changes at the level of the muscle or central nervous system failing to drive the motoneurons effectively [20, 23]. Many researchers have studied the relationship between handgrip strength and fatigue [24-26]. Bautmans et al. [25] introduce an assessment method for muscle fatigue resistance by asking the subject to sustain maximal handgrip effort as long as possible and reporting the time at which the grip force drops to 50 % of its maximum. Staszkiwicz et al. [27] studied the relationship between muscle strength and the fatigue resistance at different levels of 25%, 50%, and 75% of maximal strength (i.e. the time at which the grip force drops to 25%, 50%, and 75% of its maximum) in males and females. They found that there is a gender difference in relation to fatigue resistance at 50% of handgrip force, delivering the best knowledge about muscle endurance [27]. Alkurdi and Dweiri [22] have studied the fatigue resistance at 50% of handgrip force for different arm anatomical positions during sustained maximal handgrip effort. Their study was conducted on only twenty males' subjects. Therefore, they recommended evaluating the fatigue resistance at 25%, 50%, and 75% of the maximum grip force for a larger sample size.

This present study aims to determine the effect of gender on the maximum handgrip strength and the fatigue resistance at different levels of maximum force (i.e. the time needed for grip strength drops to 75% (FR_{75}), 50% (FR_{50}), and 25%, (FR_{25}) of the maximum grip force) during sustained maximal handgrip effort at different anatomical positions in healthy adults. Furthermore, the effect of different arm anatomical positions on maximum handgrip strength and fatigue resistance during sustained maximal handgrip effort was investigated.

Material and Methods

Participants

In this experimental study, we proposed to study the effect of gender and arm's anatomical position on the handgrip strength and endurance time. One hundred young Jordanian, undergraduate students, participated in the current study. Forty-one females with an average age of 21.8 years and fifty-nine males with an average age of 22.1 years. All participants were healthy with no history of musculoskeletal injuries or complications. The right hand was the dominant hand for all participants. Table 1 shows the subject characteristics, including age, height, weight, body mass index (BMI), and some anthropometric measures of the dominant hand of the female, males, and both combined.

Instrumentations

The system used for data collection is a commercial system developed by ADInstruments corporation. Figure 1 shows the complete setup, composed of a Grip Force Transducer (GFT) and is attached to the PowerLab unit. The PowerLab is a highly, reliable, and precise data acquisition (DAQ) unit. The GFT sensor is a pre-calibrated strain gauge based isometric dynamometer with a linear response in the 0–800 N range. The DAQ unit was connected via a USB port to a personal computer (PC). The software environment used in the data collection operation and interfaced with the hardware is the LabChart software.

Table 1: Subjects demographics, data presented as mean (standard deviation)

	Male	Female	Overall
Height (cm)	176.6 (6.7)	161.8 (5.2)	170.5 (9.5)
Weight (Kg)	75.8 (14.8)	61.3 (10.7)	69.8 (15)
Arm length (cm)	61.4 (7.1)	53.8 (4.2)	58.3 (7.1)
Forearm length (cm)	35.8 (6.6)	31.0 (2.6)	33.8 (5.8)
Hand-breadth	19.8 (4.5)	17.3 (1.5)	18.8 (3.8)
Hand length (cm)	18.6 (3.7)	14.3 (1.6)	16.8 (3.7)
Age (Years)	22.1 (1.2)	21.8 (0.9)	22 (1.1)
BMI (Kg/m²)	24.2 (3.8)	23.4 (3.8)	23.9 (3.8)

BMI: Body mass index

Procedures

At the beginning, participants were informed about the protocols and procedures adopted for the experiments. Participants were asked to sign the consent form after explaining the experiment. The study's protocol was approved by the Research Ethics Committee at the Department of Biomedical Engineering at Yarmouk University. Subject height was measured using a wall-fixed measuring tape while the subject stands on the floor next to the wall. A flexible measuring tape was used to measure the arm length, the forearm length, the hand-breadth, and the hand length, of the dominant right hand. A standard weight scale was used to measure the weight for each participant. The body mass index (BMI) was calculated using

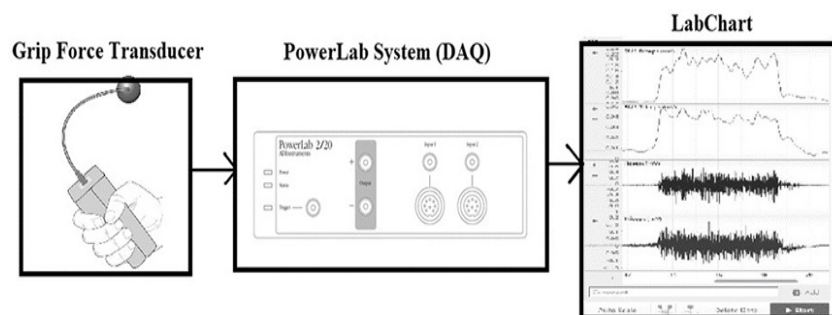

Figure 1: Block diagram of the system used in data collection.

the well-known equation where the BMI equals the weight in kilogram divided by the height in meter squared. Participants were instructed to grip the hand force transducer to their maximum capacity and to sustain the force for the longest period possible. FR_{75} , FR_{50} , and FR_{25} were measured which is the time needed for the handgrip strength to drop to 75%, 50% and 25% of its maximum strength during sustained maximal handgrip effort, respectively. The experiment was repeated for seven different anatomical positions as shown in Figure 2. Participants were asked to rest for five min after each trial. The data were recorded and saved in a computer connected to the Power Lab. Lab-Chart software was used to visualize the force-time data and find the key variables of interest for all anatomical positions. The values of the

key variables of interest, which are the maximum force and the fatigue resistances at 75 %, 50 %, and 25 % of the maximum force, were organized and saved in an Excel sheet.

Statistical Analysis

Statistical analysis was performed using a two-way factorial analysis of variance (ANOVA) using SPSS software (IBM SPSS Statistics 20). A two-way analysis of variance (ANOVA) followed by Sidak multiple comparisons test was used to determine the gender effects on grip strength and fatigue resistance. Tukey's Honest Significant Difference (HSD) post-hoc test was used to investigate the main effect of arm anatomical positions on grip strength and fatigue resistance. Probability (p) values < 0.05 were considered statistically significant.

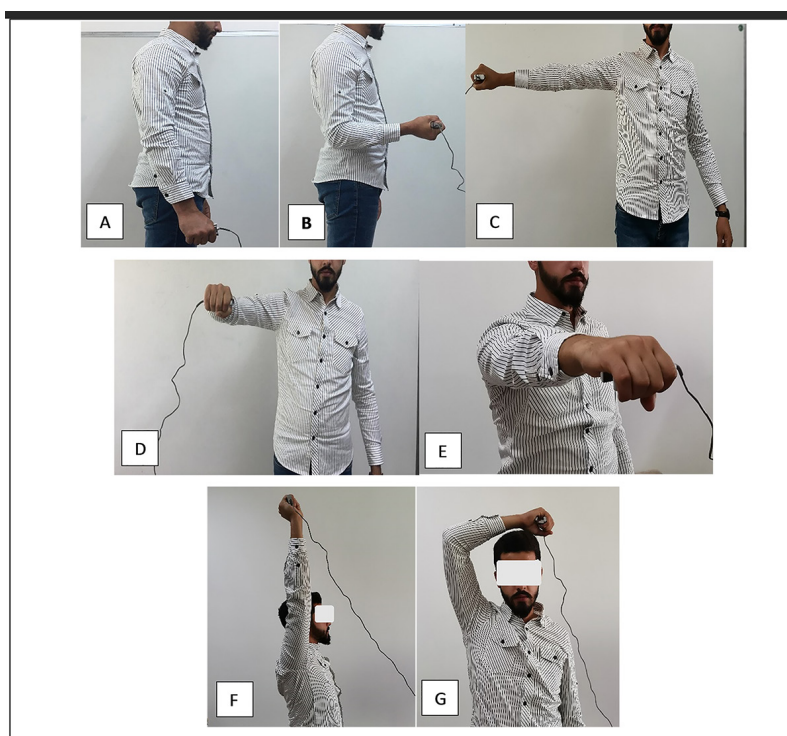

Figure 2: Different anatomical positions of the arm. A) Position 1 (P1): Arm adduction with 180° at the elbow joint. B) Position 2 (P2): Arm adduction with 90° forward at the elbow joint. C) Position 3 (P3): Arm abduction with 90° at the shoulder joint and 180° at the elbow D) Position 4 (P4): Arm abduction with 90° at the shoulder joint and 90° at the elbow joint with the forearm perpendicular to the frontal plane. E) Position 5 (P5): Arm perpendicular to the frontal plane. F) Position 6 (P6): Arm abduction with 180° at the shoulder joint and 180° at the elbow joint. G) Position 7 (P7): Arm abduction with 180° at the shoulder joint and 90° at the elbow joint

Results

The results of the two-way ANOVA for grip strength and fatigue resistance at 75% (FR_{75}), 50% (FR_{50}) and 25% (FR_{25}) of maximum strength are summarized in Table 2. The results showed significant F-ratio for gender and position main effects for grip strength, FR_{75} , FR_{50} and FR_{25} ($p < 0.01$). The interaction effect between gender and position was significant for grip strength ($p = 0.018$) while it was not significant for FR_{75} , FR_{50} and FR_{25} ($p > 0.05$).

Figure 3 summarized the results obtained using a post hoc multiple comparison test to find gender differences. The maximum grip strength was significantly higher for males as compared to females for all the seven positions ($p < 0.01$) (Figure 3A). The FR_{75} was significantly higher for males as compared to females for position 3 ($p = 0.015$), position 4 ($p = 0.039$) and position 6 ($p = 0.0017$) (Figure 3B). Figure 3C showed a significantly higher FR_{50} for males as compared to females for position 1 ($p = 0.0016$), position 3 ($p = 0.0051$), position 4 ($p = 0.0016$) and position 6 ($p < 0.001$). Furthermore, FR_{25} was significantly higher for males as compared to females for position 1 ($p = 0.0027$), position 2 ($p = 0.02$), position 3 ($p = 0.006$), position 4 ($p = 0.0045$), position 5 ($p = 0.015$) and position 6 ($p = 0.008$) (Figure 3D). Interestingly, there was no significant difference between males and females for position 7 for all the fatigue resistance times.

Figure 4 shows a bar chart representation of the maximum force, FR_{75} , FR_{50} and FR_{25} for

all included anatomical positions. The results of the position pairwise comparisons were obtained by applying Tukey's HSD post hoc test for the handgrip strength, FR_{75} , FR_{50} and FR_{25} , as shown in Figure 4. Handgrip strength was significantly higher for position 2 as compared to position 7 (Figure 4A). FR_{75} was significantly higher for position 1 as compared to position 4 and position 5. Similarly, FR_{75} was significantly higher for position 7 as compared to position 4 and position 5 (Figure 4B). Regarding FR_{50} , the time at position 7 was significantly higher than that at position 4 (Figure 4C). FR_{25} was significantly higher for position 7 as compared to position 6 (Figure 4D).

Discussion

This study aimed to determine the effect of gender on the maximum handgrip strength, and the fatigue resistance, defined as the time to drop to 75% (FR_{75}), 50% (FR_{50}) and 25% (FR_{25}) of the maximum grip force during sustained maximal handgrip effort at different anatomical positions and to investigate the effect of different arm anatomical positions on maximum handgrip strength and fatigue resistance at different levels of maximum force during sustained maximal handgrip effort in healthy adult university students. The current work reveals some important results that show a high degree of agreement with previous work on the topic.

In agreement with previous studies, the cur-

Table 2: Summary of two-way analysis of variance (ANOVA) for grip strength and fatigue resistance (FR) at 75%, 50% and 25% of maximum strength.

Source	Force (N)	FR_{75}	FR_{50}	FR_{25}
Gender	F (1, 98) = 43.27; p < 0.001	F (1, 98) = 10.97; p = 0.0013	F (1, 98) = 18.35; p < 0.001	F (1, 98) = 17.40; p < 0.001
Position	F (6, 588) = 5.697; p < 0.001	F (6, 588) = 6.920; p < 0.001	F (6, 588) = 6.948; p < 0.001	F (6, 588) = 7.977; p < 0.001
Interaction: Gender × Position	F (6, 588) = 2.568; p = 0.018	F (6, 588) = 1.594; p = 0.146	F (6, 588) = 1.040; p = 0.398	F (6, 588) = 0.522; p = 0.7918

FR: Fatigue resistance, FR_{75} , FR_{50} and FR_{25} : Time during which grip strength drops from maximum strength to 75%, 50% and 25% of maximum strength, respectively.

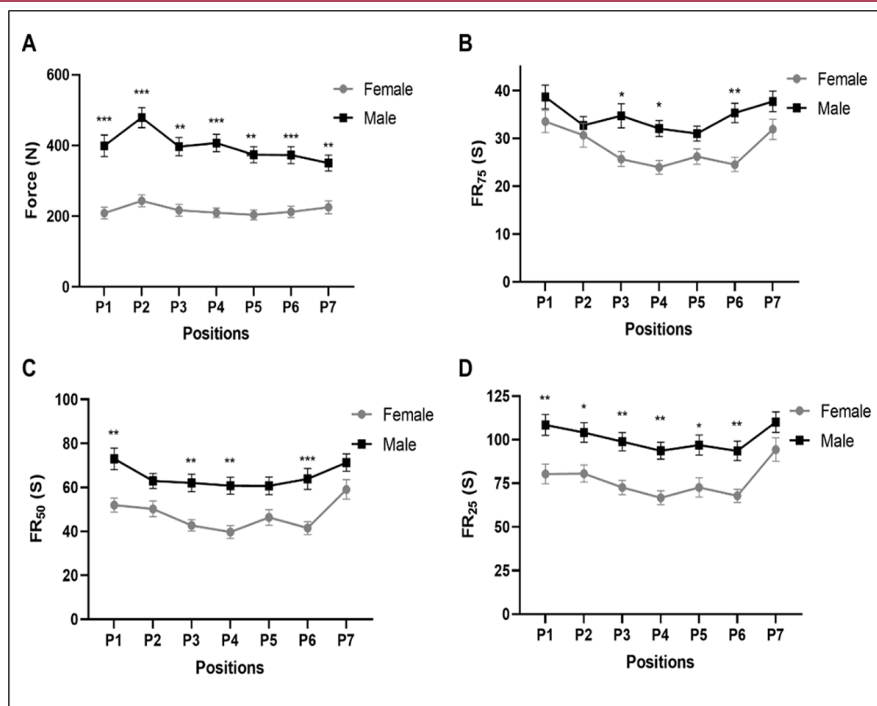

Figure 3: Handgrip strength and fatigue resistance for females and males at different arm's anatomical position. A) The handgrip strength, B) fatigue resistance at 75% (FR_{75}) of the maximal force, C) fatigue resistance at 50% of the maximal force (FR_{50}) and D) fatigue resistance at 25% (FR_{25}) of the maximal force for all anatomical positions. The values are the means \pm standard error (SE). *** $P < 0.001$, ** $P < 0.01$ and * $P < 0.05$, significant difference between males and females at each position.

rent result showed that males generate significantly higher hand grip force compared to females for all included arm anatomical position. The maximal handgrip strength was studied among 75 male and 50 female young subjects using a mechanical dynamometer [28]. For the dominant hand, the maximal hand strength was 48.6 kg and 32.9 kg on average for males and females, respectively. The maximal handgrip strength in females was 67.7% of that of males. Similarly, Maynard and Triyanti [14] described the handgrip strength and the factor associated with it among 94 Indonesian young subjects aged 18-21 years old and distributed as 47 males and 47 females. For the dominant hand, the maximal handgrip strength was 35.99 kg and 21.89 kg on average for males and females, respectively. Furthermore, Kim et al. [15] conducted a normative handgrip size values for 11,104 subjects across over Korean people's lifespan aged from 10-80 years. For Korean young aged 20-24 years, the males are

shown to have higher grip strength compared to females with 42.5 kg and 25.9 kg on average, respectively. On the other hand, the effect of gender for 200 young Taiwanese subjects on the handgrip force and their ability to excrete force by their hands was investigated using a handgrip dynamometer [16]. The Maximum strength was obtained for males with 40.4 kg compared to 28.3 kg for females on average. Hence, the maximum strength of females in Taiwan was ~70.0% that of males. Also, the handgrip strength and its association with gender, the body mass index, and hand anthropometric data for 524 Sri Lanka, undergraduate university students (350 females and 174 males), have been investigated [17]. The results of handgrip strength showed a significant difference among the different genders. The strength of the dominant hand for male students was 35.27 kg compared to 19.52 kg for females.

The current results show that the maximal handgrip strength in females was 52.4%, 50.8

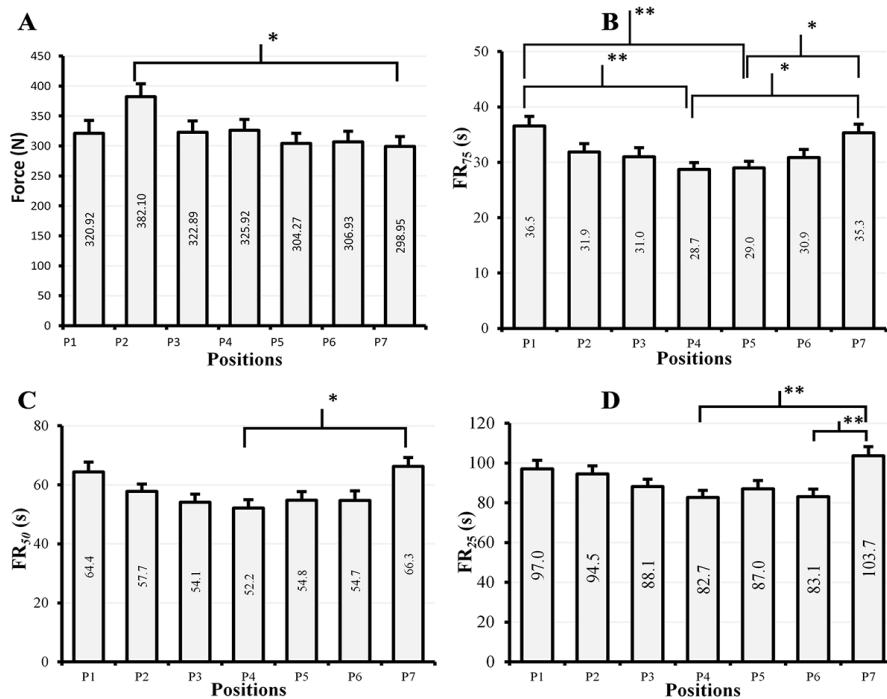

Figure 4: Handgrip strength and fatigue resistance for all arm's anatomical position. A) The handgrip strength of all anatomical positions. B) Fatigue resistance at 75% (FR_{75}) of the maximal force for all anatomical positions. C) Fatigue resistance at 50% (FR_{50}) of the maximal force for all anatomical positions. D) Fatigue resistance at 25% (FR_{25}) of the maximal force for all anatomical positions. The values are the means \pm standard error (SE). ** $P < 0.01$ and * $P < 0.05$, significant difference between two positions.

%, 54.6%, 51.6%, 54.5%, 56.9%, and 65% of that of males for positions one to seven, respectively. While, Maynard and Triyanti [14], Kim et al. [15], Liao [16], Christine [29], and Piumi et al. [17] reported that the maximal handgrip strength in females was 60.8%, 60.9%, 70%, 60% and 55.3% of that of males, respectively. Although the current results agree to a high extent with previous results, these small variations in results among the study could be explained by different body postures and hand anatomical positions adopted by each study. For example, in Kubota and Demura [28] study, the measurements were conducted while the subject was seated on a chair and their arms were straight and close to the body. In an another study, the handgrip strength was measured while the subject was seated, and their elbows were fixed at 90° [14]. Furthermore, in Kim et al. [15] study, the measurement was obtained while the participant was standing upright with their shoulders in a neutral position, the elbow is fully ex-

tended, and the arms are adducted. It has been established in the literature that different body posture and hand anatomical positions have an impact on the obtained handgrip force values [18-22]. Such a difference in muscle strength explained the variation in the ability to perform the daily basis activities between males and females. Another reason behind the reduced grip strength in females compared to males is related to the high prevalence of developing frailty as they age [30].

Fatigue resistance has been studied and compared between males and females. As shown in the results, the gender differences in fatigue resistance depend on arm anatomical positions and at which level the fatigue resistance was measured (i.e. FR_{75} , FR_{50} , and FR_{25}). For example, position 7 showed no significant differences for all fatigue resistance levels, while position 2 and 5 showed that males have higher fatigue resistance as compared with females at only 25 % of maximal force (FR_{25}). On the oth-

er hand, males have higher fatigue resistance at positions 3, 4, 6 as compared with females regardless of the fatigue resistance levels. Gupta et al. [31] have found that the 70% handgrip strength time was significantly higher for males as compared with females for 301 healthy participants aged 12-14 years old. On the contrary, Bautmans et al. [25] investigated the resistance of handgrip muscle to fatigue in elderly people (age 76.4 ± 5.4 years). In this study, the time taken by 40 elderly subjects to reach 50% of its maximal handgrip force during sustained contraction was higher in females than males with an average of 82.3s for females versus 54.0s for males. Different age groups may contribute to this variation in the literature. It has been shown that the force-time characteristics during a sustained maximal grip effort are significantly different according to age [32].

The results obtained in the current work show that the maximal handgrip force (i.e. grip strength) is significantly affected by arm's anatomical position on handgrip strength. This is in consistent with previous studies conducted to find the effect of different arm position on handgrip strength. The effect of the shoulder and elbow positions on grip strength with respect to wrist positioned in neutral and in extension during six different positions was studied for 50 healthy young students aged 18-25 years old [19]. These positions were divided into two groups, for the first group the elbow was maintained at full extension while varying the shoulder flexion angle for 0° , 90° , and 180° . For the second group, the elbow was maintained at 90° flexion while varying the shoulder flexion angle for 0° , 90° , and 180° . The highest mean grip strength among these positions was recorded when the shoulder was positioned in 180° of flexion and elbow with full extension with respect to wrist positioned in neutral (30.20 Kg) and wrist in extension (25.44 Kg). Whereas the lowest mean grip strength was recorded when the shoulder was positioned in 180° flexion with elbow 90° flexion with respect to wrist positioned in neutral (21.92 Kg) and wrist in extension (19.40 Kg). In another study, handgrip

strength for four different shoulder positions for 160 Chinese subjects (20-69 years old) was investigated [20]. Three of these positions were maintained at a full extension of the elbow and varied shoulder flexion angles (i.e. 0° , 90° , and 180°) whereas for the last position, the elbow was flexed at 90° and the shoulder was flexed at 0° . Among these positions, the highest mean handgrip strength was when both shoulder and elbow were at full extension (87.6 Kg) whereas the lowest mean strength was recorded with 0° flexion of shoulder and 90° flexion of the elbow (82.2 Kg). Furthermore, Mathiowetz et al. [21] have compared the grip strength between extended and 90° flexed elbow while maintaining 0° flexion shoulder angle for 29 females aged between 20 to 34 years old. Mathiowetz and his colleagues found that grip-strength scores were significantly higher when the elbow was flexed with 90° (69.2 Kg) as compared to when the elbow was fully extended (66.7 Kg).

Kurdi and Dweiri have studied the handgrip strength at seven different anatomical positions [22] that were the same as those investigated in the current study. Despite the small sample size, where only twenty males' subjects were recruited in their study, the descriptive result showed that the largest grip strength was obtained at position 2 in which the shoulder adducted and the elbow was at 90° flexion, whereas the lowest grip size was recorded at position 7 in which the shoulder abducted with 180° and 90° at the elbow joint. The pairwise comparisons between all arm anatomical positions in the current study showed that the only significant difference is found between position 2 and position 7. Position 2 generates significantly higher handgrip force as compared to position 7. These findings are compatible with what has been found in [22] and with results for the standardized testing protocol given by [33].

Conclusion

The results of this study confirmed the significant effect of gender on the maximal handgrip strength. Higher grip strength has been re-

ported for males as compared to females. The current work showed that gender difference in fatigue resistance depends on fatigue resistance levels. To the authors' best knowledge, this is the first study, investigating the fatigue resistance at various levels of the maximal handgrip force for different arm anatomical positions. The results in this study show that the fatigue resistance is significantly influenced by the anatomical position of the arm. Further studies are needed to investigate how other factors such as age, height, weight, hand size, and upper arm size may affect the handgrip strength and endurance for different anatomical positions.

Authors' Contribution

SF. Almashaqbeh was responsible for the conceptualization of the research idea, supervising data collection, and also contributing to the writing and editing of the final manuscript. S. Al-Momani contributed to the writing of the literature review and in the discussion of the obtained results. A. Khader was responsible for the design of the statistical analysis, obtaining results, writing and editing of the final manuscript, and in the response to the reviewer's comments. Q. Qananwah contributed to the literature review and the writing of the final manuscript. S. Marabeh, R. Maabreh, A. Al badarneh, and K. Abdullah were responsible for the data collection and analysis. Furthermore, they contributed to the conceptualization of the research idea. All the authors read, modified, and approved the final version of the manuscript.

Ethical Approval

The study's protocol was approved by the Research Ethics Committee at the Department of Biomedical Engineering at Yarmouk University.

Informed consent

All participants signed the consent form before entering the study.

Funding

This research was supported by the Deanship of Scientific Research at Yarmouk University, Irbid, Jordan.

Conflict of Interest

None

References

1. Waldo B. Grip strength testing. *Natl Strength Condit Assoc J.* 1996;**18**(5):32–5.
2. Mathiowetz V, Weber K, Volland G, Kashman N. Reliability and validity of grip and pinch strength evaluations. *J Hand Surg Am.* 1984;**9**(2):222-6. doi: 10.1016/s0363-5023(84)80146-x. PubMed PMID: 6715829.
3. Tietjen-Smith T, Smith SW, Martin M, Henry R, Weeks S, Bryant A. Grip Strength in Relation to Overall Strength and Functional Capacity in Very Old and Oldest Old Females. *Phys Occup Ther Geriatr.* 2006;**24**(4):63-78. doi: 10.1080/J148v24n04_05.
4. Saremi M, Rostamzadeh S. Hand dimensions and grip strength: a comparison of manual and non-manual workers. Proceedings of the 20th Congress of the International Ergonomics Association (IEA 2018); Springer, Cham; 2018. p. 520-9.
5. Cooper R, Kuh D, Cooper C, Gale CR, Lawlor DA, Matthews F, Hardy R, et al. Objective measures of physical capability and subsequent health: a systematic review. *Age Ageing.* 2011;**40**(1):14-23. doi: 10.1093/ageing/afq117. PubMed PMID: 20843964. PubMed PMCID: PMC3000177.
6. Bohannon R. Hand-Grip Dynamometry Predicts Future Outcomes in Aging Adults. *J Geriatr Phys.* 2008;**31**(1):3-10. doi: 10.1519/00139143-200831010-00002. PubMed PMID: 18489802.
7. Nofuji Y, Shinkai S, Taniguchi Y, Amano H, Nishi M, Murayama H, Fujiwara Y, Suzuki T. Associations of Walking Speed, Grip Strength, and Standing Balance With Total and Cause-Specific Mortality in a General Population of Japanese Elders. *J Am Med Dir Assoc.* 2016;**17**(2):184.e1-7. doi: 10.1016/j.jamda.2015.11.003. PubMed PMID: 26717805.
8. Rantanen T. Muscle strength, disability and mortality. *Scand J Med Sci Sports.* 2003;**13**:3-8. doi: 10.1034/j.1600-0838.2003.00298.x. PubMed PMID: 12535311.
9. Cruz-Jentoft AJ, Baeyens JP, Bauer JM, et al. Sarcopenia: European consensus on definition and diagnosis: Report of the European Working Group on Sarcopenia in Older People. *Age Ageing.* 2010;**39**(4):412-23. doi: 10.1093/ageing/afq034. PubMed PMID: 20392703. PubMed PMCID: PMC2886201.
10. Fried L, Tangen C, Walston J, Newman A, Hirsch C, Gottdiener J, et al. Frailty in Older Adults Evidence for a Phenotype. *J Gerontol A Biol Sci Med Sci.* 2001;**56**:M146-56. doi: 10.1093/gerona/56.3.m146. PubMed PMID: 11253156.
11. Bohannon RW. Grip Strength: An Indispensable Biomarker for Older Adults. *Clin Interv Aging.* 2019;**14**:1681-91. doi: 10.2147/CIA.S194543. PubMed PMID: 31631989. PubMed PMCID:

- PMC6778477.
12. Denk K, Lennon S, Gordon S, Jaarsma RL. The association between decreased hand grip strength and hip fracture in older people: A systematic review. *Exp Gerontol.* 2018;**111**:1-9. doi: 10.1016/j.exger.2018.06.022. PubMed PMID: 29969664.
 13. Kim SW, Lee HA, Cho EH. Low handgrip strength is associated with low bone mineral density and fragility fractures in postmenopausal healthy Korean women. *J Korean Med Sci.* 2012;**27**(7):744-7. doi: 10.3346/jkms.2012.27.7.744. PubMed PMID: 22787368. PubMed PMCID: PMC3390721.
 14. Maynard, Triyanti V. Evaluation of the Correlation Between Hand Anthropometry and Grip Strength in Sedentary Undergraduate Students. *International Journal of Advances in Computer Science and Technology.* 2016;**5**(3):38-46.
 15. Kim M, Won CW, Kim M. Muscular grip strength normative values for a Korean population from the Korea National Health and Nutrition Examination Survey, 2014-2015. *PLoS One.* 2018;**13**(8):e0201275. doi: 10.1371/journal.pone.0201275. PubMed PMID: 30125289. PubMed PMCID: PMC6101358.
 16. Liao KH. Experimental study on gender differences in hands and sequence of force application on grip and hand-grip control. *Int J Occup Saf Ergon.* 2014;**20**(1):77-90. doi: 10.1080/10803548.2014.11077039. PubMed PMID: 24629882.
 17. Piumi N, Jinali M, Janeesha N, Thirunavukarasu N, et al. Descriptive study of hand grip strength and factors associated with it in a group of young undergraduate students in university of peradeniya, sri lanka who are not participating in regular physical training. *Int J Physiother.* 2019;**6**(3):82-8. doi: 10.15621/ijphy/2019/v6i3/183876.
 18. Elsaïs W, Mohammad W. Influence of different testing postures on hand grip strength. *Eur Sci J.* 2014;**10**(36):290-301.
 19. Parvatikar V, Mukkannavar P. Comparative Study of Grip Strength in Different Positions of Shoulder and Elbow with Wrist in Neutral and Extension Positions. *Journal of Exercise Science & Physiotherapy.* 2009;**5**:67-75.
 20. Su CY, Lin JH, Chien TH, Cheng KF, Sung YT. Grip strength in different positions of elbow and shoulder. *Arch Phys Med Rehabil.* 1994;**75**(7):812-5. PubMed PMID: 8024431.
 21. Mathiowetz V, Rennells C, Donahoe L. Effect of elbow position on grip and key pinch strength. *J Hand Surg Am.* 1985;**10**(5):694-7. doi: 10.1016/s0363-5023(85)80210-0. PubMed PMID: 4045150.
 22. Alkurdi Z, Dweiri Y. A Biomechanical Assessment of Isometric Handgrip Force and Fatigue at Different Anatomical Positions. *J Appl Biomech.* 2010;**26**:123-33. doi: 10.1123/jab.26.2.123. PubMed PMID: 20498483.
 23. Gandevia S. Spinal and Supraspinal Factors in Human Muscle Fatigue. *Physiol Rev.* 2001;**81**:1725-89. doi: 10.1152/physrev.2001.81.4.1725. PubMed PMID: 11581501.
 24. Cotelez L, Serra M, Ramos E, Zaia J, Toledo F, Quemelo P. Handgrip strength and muscle fatigue among footwear industry workers. *Fisioter Mov.* 2016;**29**(2):317-24. doi: 10.1590/0103-5150.029.002.AO10.
 25. Bautmans I, Gorus E, Rose N, Mets T. Handgrip performance in relation to self-perceived fatigue, physical functioning and circulating IL-6 in elderly persons without inflammation. *BMC Geriatr.* 2007;**7**:5. doi: 10.1186/1471-2318-7-5. PubMed PMID: 17331228. PubMed PMCID: PMC1820598.
 26. Ahmed T. The Effect of Upper Extremity Fatigue on Grip Strength and Passing Accuracy in Junior Basketball Players. *J Hum Kinet.* 2013;**37**:71-9. doi: 10.2478/hukin-2013-0027. PubMed PMID: 24146707. PubMed PMCID: PMC3796845.
 27. Staszkiwicz R, Ruchlewicz T, Szopa JAN. Handgrip strength and selected endurance variables. *J Hum Kinet.* 2002;**7**:29-42.
 28. Kubota H, Demura S. Gender differences and laterality in maximal handgrip strength and controlled force exertion in young adults. *Health.* 2011;**3**(11):684-8. doi: 10.4236/health.2011.311115.
 29. Christine LW. Women, sport & performance: A physiological perspective. Michigan: Human Kinetics Publishers; 1985.
 30. Falsarella GR, Gasparotto LP, Barcelos CC, Coimbra IB, Moretto MC, Pascoa MA, Ferreira TC, Coimbra AM. Body composition as a frailty marker for the elderly community. *Clin Interv Aging.* 2015;**10**:1661-6. doi: 10.2147/CIA.S84632. PubMed PMID: 26527868. PubMed PMCID: PMC4621187.
 31. Gupta M, Jindal M, Nanda B, Suri S. Relationship of Hand-Grip Strength and Endurance Time With an Individual's Anthropometric Parameters-A Study in Adolescent Population of Jammu. *International Journal of Current Medical and Applied Sciences.* 2017;**14**:119-23.
 32. De Dobbeleer L, Beyer I, Rose N, Pleck S, Zonnekei N, Mets T, et al. Force-time characteristics during sustained maximal handgrip effort according to age and clinical condition. *Exp Gerontol.* 2017;**98**:192-98. doi: 10.1016/j.exger.2017.08.033. PubMed PMID: 28864229.
 33. Fess E, Moran C. Clinical assessment recommendations. American Society of Hand Therapists; 1981.